

SEVCON®

Partner with Performance

Gen4

AC MOTOR CONTROLLER

An AC motor controller designed to meet the high performance requirements of on-road and off-road Electric (EV) and Hybrid Electric Vehicles (HEV).

A compact, rugged and cost effective design, the Gen4 Size 8 is well suited for EV OEMs, EV conversions and EV drive train system integrators.

Its high voltage range, up to 400VDC, is well matched to the needs of the automotive and commercial transport markets. The same hardware platform handles both AC Induction and Permanent Magnet AC motor technologies.

FEATURES

- AC Permanent Magnet synchronous motor
- AC Induction motor
- Up to 400V DC supply voltage
- Up to 100kW peak power output
- Up to 60kW continuous power output
- Advanced flux vector control
- Integrated logic circuit
- Includes an additional dedicated safety supervisory processor
- 12V or 24V nominal supply
- Designed for ISO26262 ASIL C compliance
- Safety interlock pulsed enable signal



Gen4

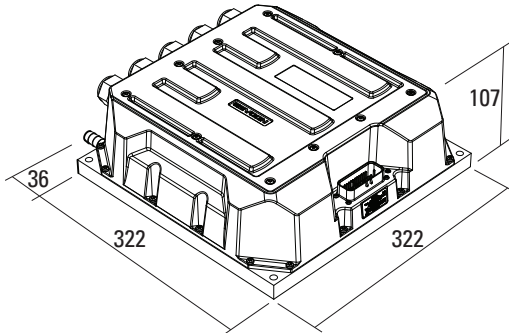

SEVCON[®]

Partner with Performance

Sevcon Ltd Kingsway South
Gateshead NE11 0QA England
T +44 (0191) 497 9000
sales.uk@sevcon.com

Sevcon Inc 155 Northboro Road
Southborough MA01772 USA
T +1 (508) 281 5500
sales.us@sevcon.com

Sevcon SAS Parc d'Activité
du Vert Galant Rue Saint Simon
St Ouen l'Aumône
95041 Cergy Pontoise Cedex France
T +33 (0)1 34 30 35 00
sales.fr@sevcon.com

Sevcon Japan K.K.
Kansai Office 51-26 Ohyabu Hikone
Shiga Japan 522-0053
T +81 (0) 7 49465766
jp.info@sevcon.com

Sevcon Asia Ltd
Room No.202 Dong-Ah Heights Bldg
449-1 Sang-Dong Wonmi-Gu
Bucheon City Gyeonggi-Do
420-816 Korea
T +82 32 215 5070
sales.kr@sevcon.com

Sevcon Germany
Hintere Str.32
73266 Bissingen an der Teck
Germany
T: +49 (0)170 9980294
E: de.info@sevcon.com

 follow @Sevcon
www.sevcon.com

KEY PARAMETERS

- Operating voltage range 128V to 400 VDC
- Output motor phase current:
 - 360 Arms (30sec)
 - 300 Arms (2 min)
 - 200 Arms (Continuous)
- Water/Glycol or forced air cooling. Oil cooling available - contact Sevcon
- Safety:
 - Electrical safety to ISO 6494, IEC 60664 and UL840
 - Functional safety to ISO26262
 - Pulsed safety enable input
 - Pulsed status output
- Environmental:
 - -40°C to +85°C operation
 - IP6k9k and IP67 protection
 - ISO 16750
- Weight 10kg

MULTIPLE MOTOR SENSOR FEEDBACK OPTIONS

The Gen4 Size 8 supports various types of motor sensor via range of hardware inputs and software control, allowing a great deal of flexibility.

- Absolute UVW encoder input
- Absolute Sin/Cos encoder input
- Resolver input
- Incremental AB encoder input
- Programmable 5V to 10V encoder power supply

INTEGRATED I/O

The Gen4 Size 8 includes a fully-integrated set of inputs and outputs (I/O) designed to handle a wide range of vehicle functions. This eliminates the need for additional external I/O modules or vehicle controllers and connectors.

- All I/O protected to 40V
- 4 analogue inputs 0-10V
- 4 digital inputs
- 3 power supplies 0-10V 100mA
- 3 digital outputs PWM max 2A

OTHER FEATURES

- A CANopen bus allows easy interconnection of controllers and devices such as displays and driver controls.
- The CAN bus allows the user to wire the vehicle to best suit vehicle layout since inputs and outputs can be connected to any of the controllers on the vehicle and the desired status is passed over the CAN network to the relevant motor controller.
- The Gen4 Size 8 controller can dynamically change the allowed battery current by exchanging CAN messages with a compatible Battery Management System.
- Configurable as vehicle control master or motor slave

CONFIGURATION TOOLS

Sevcon offers a range of configuration tools for the Gen4 Size 8 controller, with options for Windows based PC or calibrator handset unit. These tools provide a simple yet powerful means of accessing the CANopen bus for diagnostics or parameter adjustment. The handset unit features password protected access levels and a customized logo start-up screen.

